

Valuing Innovation-Based Investments with the Weighted Average Polynomial Option Pricing Model.

Elena Rogova¹, Andrey Yarygin²

National Research University Higher School of Economics,
55-2 Sedova Ulitsa, Saint-Petersburg 192171, Russia

January, 23, 2012

Abstract.

This paper contains the analysis of pitfalls connected with innovation-based investments valuation. Being long-term projects with high uncertainty, innovation-based investments suffer from different types of mistakes if traditional discounted cash flow methodology is used for their valuation. The real options approach is being used for a long time, but this paper proposes an original approach based upon the consideration of the wide variety of project implementation scenarios. The weighted average polynomial option pricing model presented here may help investors to increase the quality of decisions about their participation in innovation-based opportunities.

JEL classification: D81, D92, G32.

Keywords: Real Options, Investment Valuation, Black-Scholes Option Pricing Model (BSOPM), Cox-Ross-Rubinstein Binomial option pricing model (BOPM), Weighted Average Polynomial Option Pricing Model (WAPOPM).

¹ Dr. of Economics, Professor. E-mail: rogoval@hse.spb.ru

² Post-graduate student. E-mail: andrey.yarygin@gmail.com

1. Introduction.

The strongest companies in different sectors of economy demonstrate leading market position, high return on assets and equity, rapid capitalization growth. Their success could be explained mostly by creation, transfer and commercialization of unique technologies. Undoubtedly it is a very attractive course of development for any company and for any economy in whole. See, for example, Tsujimura (2010) and Ettl (1998) for more detail. However high-technology projects differ from traditional investments by next features:

- Extended uncertainty – very often it has irregular nature, i.e. it is impossible to formulate any reliable hypothesis about the probability distribution of key parameters;
- Problems in strategic effect valuation.

Discounting Cash Flow Method (DCF) with Net Present Value (NPV) as a main criterion is the most widespread analytical tool for Investments Valuation. Though this approach besides some unrealistic assumptions (i.e. Ideal market conditions), has two fundamental inaccuracies concerning especially high-technology investments:

1. An investor's flexibility ignoring;
2. Incorrectness of the risk calculation in the denominator³.

The first one means that an investor is considered as a passive subject who does not change his decision, even if the decision had been made in the far past and market conditions have changed since. In other words, DCF Method does not take into account any new unexpected market information which comes during the project lifetime. Changes in legislation, sudden competitor's actions, new technology, exact experiment results and others are examples of opportunities and threats that may change investor's behavior and strategy. Investors can force projects or stop them relying on the new market information. The second one means that risk calculation in the denominator by the cumulative discounting rate does not solve the problem of considering high risk in innovation-driven projects. Incorrectness arises by reason of decreasing value to the present moment not only for Cash In-Flows, but also for Out-Flows. This situation is associated with the fact that discounting to the present value gives us correct values only if sequence of cash flows is standard. We may propose following ways to overcome two mentioned problems:

1. → Investors' flexibility valuation;
2. → Risk calculation in the numerator by the scenarios tree (or decision tree).

A leading analytical tool for implementing these ways to decrease uncertainty of the high-technology projects is the Real Option Valuation (ROV) (Trigeorgis 1996, Hull). This idea as many others is borrowed from the stock market where investor's opportunity, but not the obligation to sell or to buy an active is valued.

³ A simple example is brought in the Appendix 1.

We suppose that the plenty of researches devoted to the ROV method may be divided into two parts:

1. strong mathematic works which sometimes do not give the clear way of using results in practice (Turnbull 1987, Wilmott 1995);
2. papers devoted to method popularization (Leslie 1997).

Our paper attempts to stand on the intersection of mentioned groups. On the one hand it pretends to develop the ROV methodology for more precise estimations for the sake of investor's interest. On the other hand it allows financial managers to use quite easy analytical algorithm of calculations in contrast to, for example, difficult stochastic processes (Bastian-Pinto 2010) or continuous-state Markov (jump) process (Grillo 2010).

Almost all Option Valuation models can be divided into two main groups: models based on the Black-Scholes Option Pricing Model (BSOPM) (Black 1973) and the ones based on the Cox-Ross-Rubinstein Binomial option pricing model (BOPM) (Cox 1979). However an application of these methods to the innovation-based investments evaluation shows us their weak features:

- BSOPM is based on the continuous time assumption. This implies a possibility to sell or buy a share in the innovation project at any moment. Such assumption seems unrealistic concerning R&D investment projects;
- BSOPM is based on the replicated portfolio assumption. It is also unrealistic concerning R&D investment projects;
- BOPM is based strictly on the binomial changes assumption. It is too strong restriction concerning R&D investment projects. Though researchers still have to concede to it (Pennings 2010).

So the pitfalls of these models promote the objective of the research: developing Real Option Valuation Method for more precise estimations on which investors can rely on. The Summary of the Weaknesses in the traditional valuation methods concerning innovation-based investments is in the Appendix 2.

2. The Methodology.

In this work we propose Weighted Average Polynomial Option Pricing Model (WAPOPM). Binomial option pricing model has more realistic than BSOPM assumptions for the case of real investments, such as R&D projects. Therefore BOPM is considered as a basic method in our work. Moreover decision trees enable taking risk into account in the DCF numerator by different scenarios. We are aimed to construct a decision tree with **any possible** complex structure (any time-intervals between the project's stages, t and any amount of the scenarios at each stage), for example as you can see on figure 1.

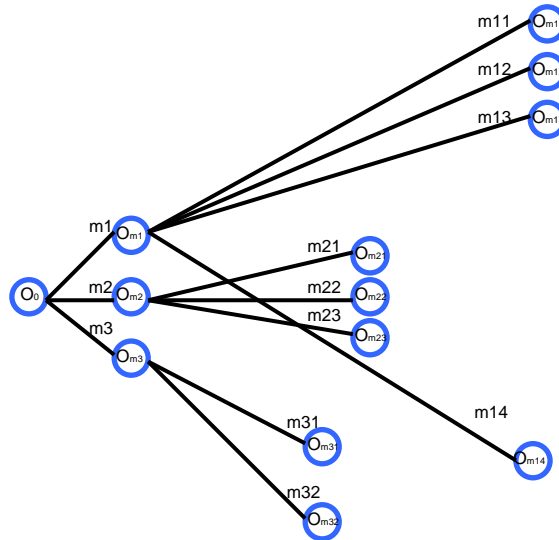

Figure 1. An Example of the R&D Project's Structure.

Introduce denotes as:

- O – Option's Value
- i – order of the possible path from the parent node
- y – a number of possible paths from the parent node
- m_i – a parameter which reflects change in basic asset price
- mapping with tradition denotes is: $m_1 \equiv u$, $m_y \equiv d$.

Each specific R&D project leads to corresponding decision tree. This results in an impracticability of deriving a unique analytical formula for real option value at the initial moment of time. Though we can propose a unique analytical algorithm of calculation in any subtree (part of the tree constructed from parent node and its children nodes). For example, there are 4 subtrees on the figure 1 (O_0 and O_{m1} , O_{m2} , O_{m3} ; O_{m1} and O_{m11} , O_{m12} , O_{m13} , O_{m14} ; O_{m2} and O_{m21} , O_{m22} , O_{m23} ; O_{m3} and O_{m31} , O_{m32}).

Real option value in the leaves (terminal nodes) is defined by famous logical limitations using input data:

$$\text{Call-option value} \equiv O_{\text{call}} = \max \{A_T - Ex ; 0\} \quad (1)$$

$$\text{Put-option value} \equiv O_{\text{put}} = \max \{Ex - A_T ; 0\} \quad (2)$$

where:

- A_T – basic asset price at the moment T . In case of real investments it is an amount of money an investor⁴ acquires. A_T depends on A_0 (basic asset price at the initial moment of time) and parameters m_i from the root to the leaves;
- Ex – option exercise price. It is defined by the contract with an investor.

⁴ or, for example, parent company which is financing R&D project

After real option value calculation at the leaves we calculate ROV at the parent node of these leaves. By iterative process we evaluate ROV at the root which is our goal.

Let us consider an innovation project that has 3 possible scenarios (Figure 2):

1. Successful;
2. Nonprofitable and breakeven;
3. Detrimental.

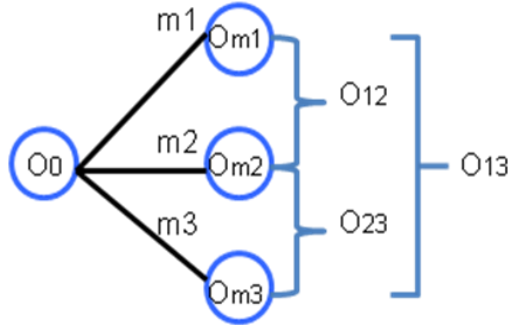

Figure 2. An Example with the $y = 3$.

Then we can get 3 estimations for the ROV at the parent node O_0 : O_{12} , O_{13} and O_{23} . Total amount of such estimations is a simple combination from “ y ” by 2

$$C_y^2 = \frac{y!}{2! (y-2)!} \quad (3)$$

Each estimation equals:

$$O_{ij} = \frac{pO_i + (1-p)O_j}{(1+r_{free})^t} \quad (4)$$

Where:

$$p = \max\left(0; \frac{(1+r_{free})^t - m_j}{m_i - m_j}\right) \quad (5)$$

Denotes which are used:

- r_{free} – risk free rate;
- i belongs to $[1 ; y - 1]$;
- j belongs to $[2 ; y]$;
- $j > i$.

A key question is how to obtain ROV of the parent node O_0 from the estimations O_{12} , O_{13} , O_{23} . If we have only two possible ways ($y = 2$), then we would use famous and simple BOPM algorithm. The last one is based on the equal portfolio value assumption regardless of the way (basic asset price change). The portfolio consists from basic asset, risk-free obligations and an option on them. We can not ignore Cox-Ross-Rubinstein's remark (Cox 1979):

“... from either the hedging or complete markets approaches, it should be clear that three-state or trinomial stock price movement will not lead to an option pricing formula based solely on arbitrage considerations.”

In other words in the next combined equations (6):

$$\begin{cases} \Delta Su + rB = C_u \\ \Delta Sd + rB = C_d \\ C = \Delta S + B \end{cases} \quad (6)$$

there are 3 equations and there are 3 unknown variables. If we introduce new unknown variable we should introduce additional equation.

Weighted Average Polynomial Option Pricing Model (WAPOPM) suggests next equation for this purpose:

$$O_o = \frac{\sum_{i=1}^{y-1} \sum_{j=i+1}^y (O_{ij}(w_i + w_j))}{(y-1) \sum_{i=1}^y w_i} \quad (7)$$

where weights w_i are defined as:

$$w_i = |1 - m_i|_5 \quad (8)$$

The equation 7 economic sense may be interpreted in the following way: we assume that **portfolio value is equal regardless of the couple ways we take** (whether 1 and 2 or 1 and 3 or 2 and 3 ... or i and j). This is basic non-arbitrage WAPOPM assumption.

Thereby all estimations O_{ij} are multiplied on the sum of weights w_i and w_j which lead to this estimation and WAPOPM evaluates ROV at the parent node O_0 . It should be noticed that Binomial option pricing model is the particular case of the WAPOPM where “y” equals 2^6 .

⁵ We suppose that such weights are better than $w_i = \frac{1}{m - m_i}^2$ or $w_i = 1 - m_i^2$

⁶ See Appendix 3.

Let us remind an extremely important issues that:

- ROV does not depend on probabilities of ascending to any specific leaf;
- Estimations which we can obtain by using risk-neutral method are equal to estimations which we can obtain by using Arbitrage Pricing Theory (APT) and they do not depend on investor's attitude to risk.

Finally, let us summarize a unique analytical algorithm of calculations in any subtree, which is intended especially for financial managers, for using in the practice:

1. to define technological input data (a decision tree which reflects particularities of the Innovation project, time-intervals between the project's stages t). Engineering and Marketing departments should play a main role at this step;
2. to define financial input data (risk-free rate r_{free} , basic asset price at the initial moment of time A_0 , option exercise price Ex);
3. to define parameters m_i (we suggest using Fuzzy Sets Theory in case of poor statistic data);
4. to calculate ROV at the leaves;
5. to evaluate ROV at the root by iterative process using WAPOPM in all subtrees.

3. Numerical WAPOPM Illustration.

R&D project "Photocatalytic isotope separation with the semiconductor nanoparticles application" was presented in the Russian Innovation Contest - 2010 (Reference #13). The essence of this innovation is in the Carbon C_{12} and C_{13} isotope separation performance increasing. Those isotopes are widely used in the nuclear and medicine industries. Let us consider this R&D project if investor wants a put-option to abandon the project in 3 years⁷ (project life is 5 years).

Step 1 - to define technological input data. Engineering and Marketing Departments took into account all possible R&D problems and constructed most likely scenario (Figure 3).

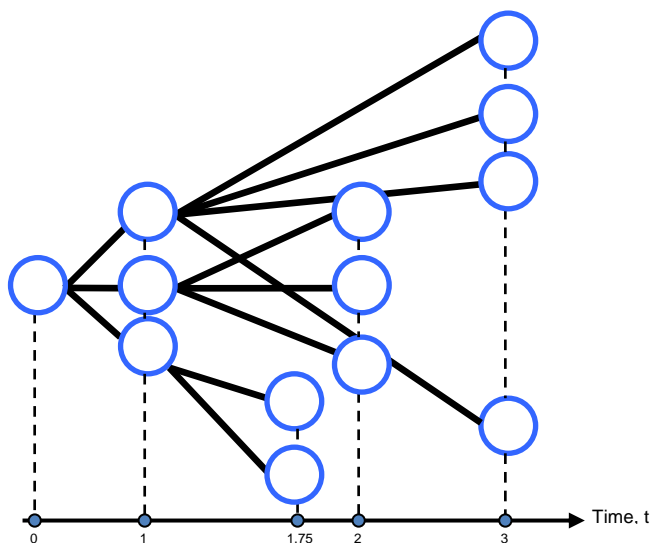

Figure 3. Step 1 – Technological input data definition.

⁷ This is illustrative example of WAPOPM application.

Step 2 - to define financial input data. Finance Department with Investor estimated initial investments in 6,2 RUR millions, an abandon put-option exercise price in 6,0 RUR millions and risk-free rate in 8% (Figure 4).

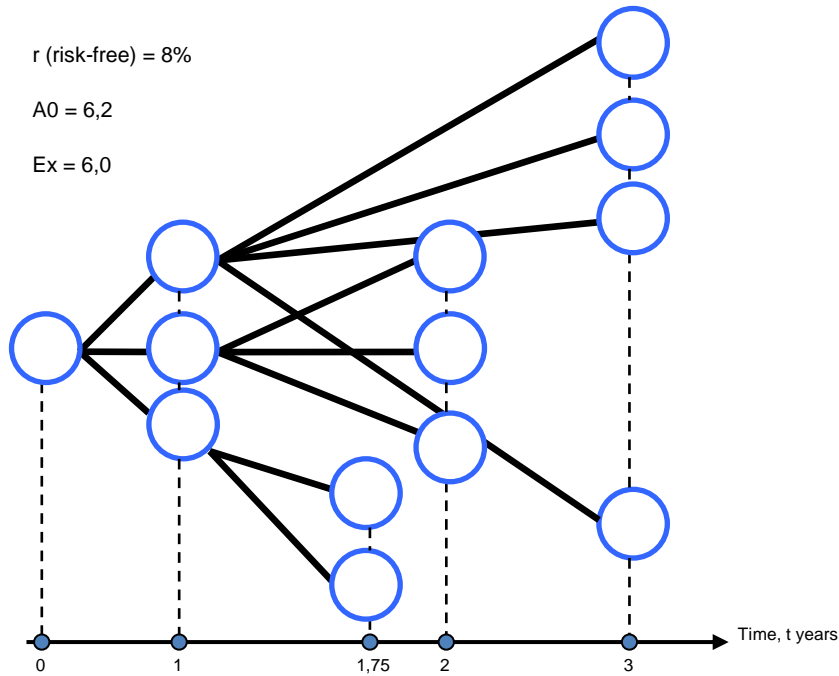

Figure 4. Step 2 – Financial input data definition.

Step 3 - parameters m_i definition. It is perhaps most difficult stage. Because of poor statistical data Fuzzy-sets were used. Trees below show basic asset value transformation (Figure 5, 6).

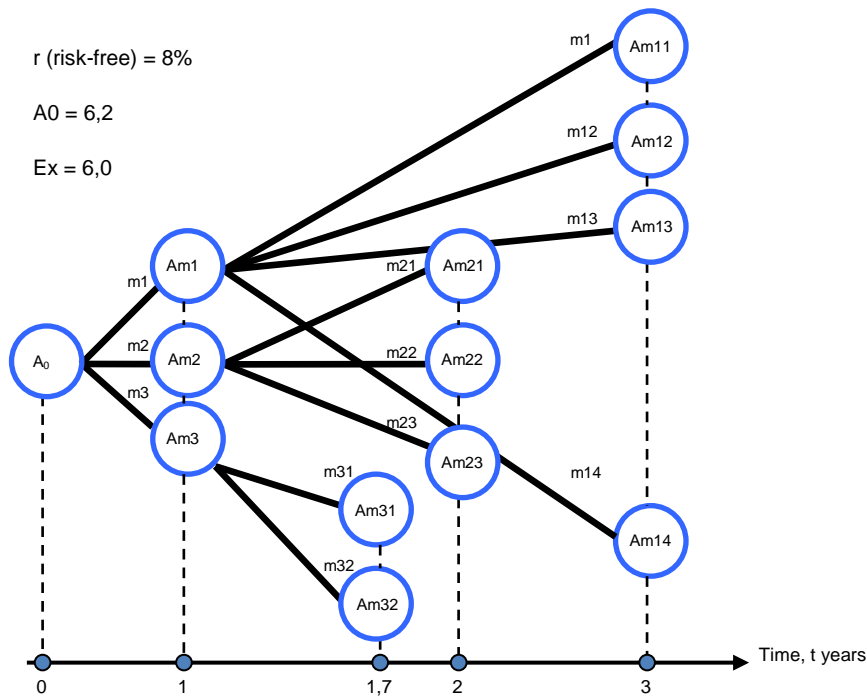

Figure 5. Step 3 - Parameters m_i estimation.

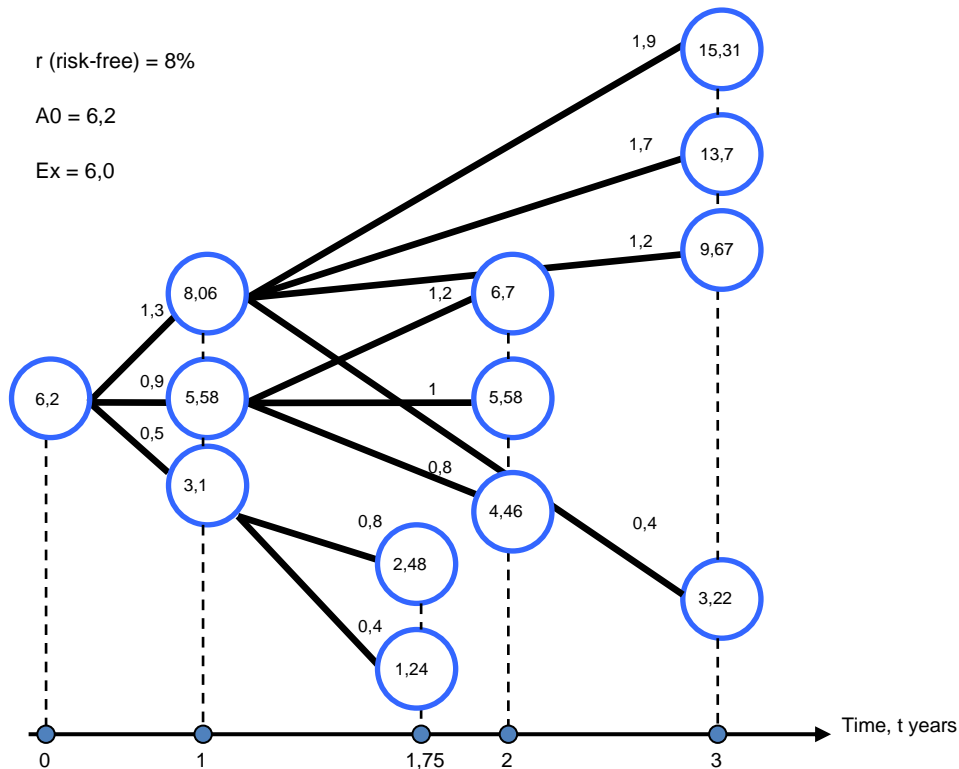

Figure 6. Step 3 - Parameters m_i estimating.

Step 4 – To definite Put-option value at the leaves of the innovation tree we use equations 1 and 2 (Figure 7).

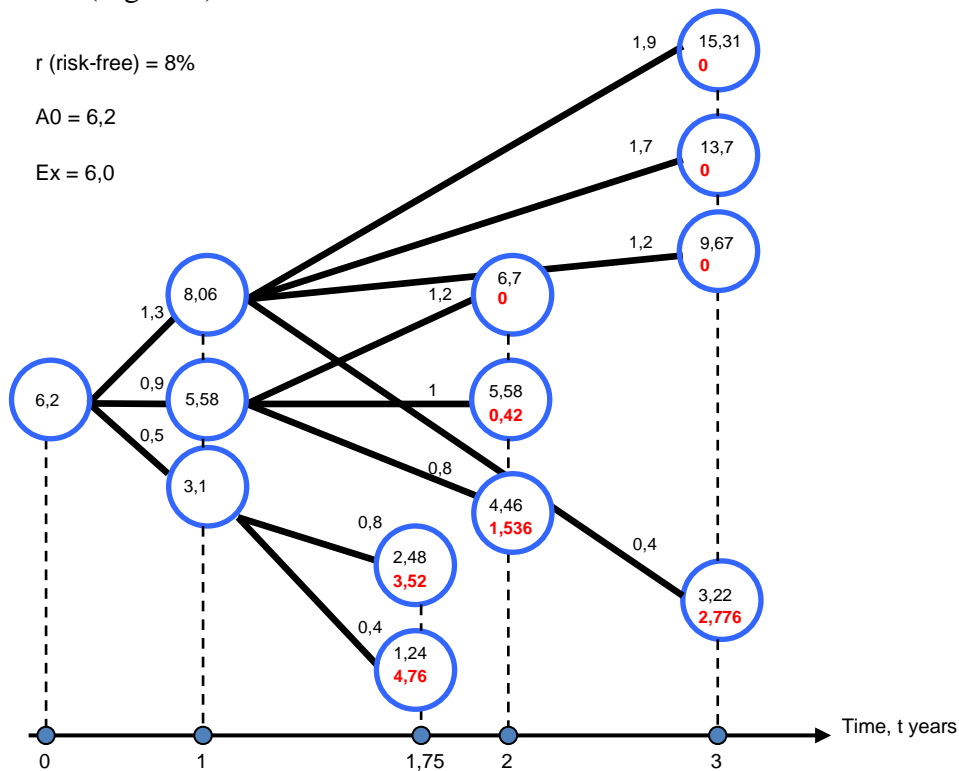

Figure 7. Step 4 - Put-option value at the leaves of the innovation tree.

Let us consider in detail WAPOPM application if we are in one concrete subtree. For example in the A_{m1} node. Then our subtree consists from parent node A_{m1} and children nodes A_{m11} , A_{m12} , A_{m13} and A_{m14} . We have got 4 different scenarios ($y = 4$), consequently total amount of option value estimations is:

$$C_y^2 = \frac{y!}{2! (y-2)!} = \frac{4!}{2!*2!} = \frac{12}{2} = 6 \quad (9)$$

According to the equation #5 variable p_{ij} possesses the values:

1. p_{12} (from the ways m_{11} and m_{12}) = $\max\left(0; \frac{(1+r_{free})^t - m_2}{m_1 - m_2}\right) = \max\left(0; \frac{(1+0,08)^2 - 1,7}{1,9 - 1,7}\right) = 0$
2. p_{13} (from the ways m_{11} and m_{13}) = 0
3. p_{14} (from the ways m_{11} and m_{14}) = 0,511
4. p_{23} (from the ways m_{12} and m_{13}) = 0
5. p_{24} (from the ways m_{12} and m_{14}) = 0,59
6. p_{34} (from the ways m_{13} and m_{14}) = 0,958

According to the equation #4 variable O_{ij} possesses the values:

1. O_{12} (from the ways m_{11} and m_{12}) = $\frac{p_{12}O_1 + (1-p_{12})O_2}{(1+r_{free})^t} = \frac{0*0 + 1*0}{(1+0,08)^2} = 0$
2. O_{13} (from the ways m_{11} and m_{13}) = 0
3. O_{14} (from the ways m_{11} and m_{14}) = 1,164
4. O_{23} (from the ways m_{12} and m_{13}) = 0
5. O_{24} (from the ways m_{12} and m_{14}) = 0,977
6. O_{34} (from the ways m_{13} and m_{14}) = 0,1

According to the equation #8 the sum of variables $(w_i + w_j)$ possesses the values:

1. $(w_i + w_j)_{12}$ (from the ways m_{11} and m_{12}) = $|1 - m_1| + |1 - m_2| = |1 - 1,9| + |1 - 1,7| = 0,9 + 0,7 = 1,6$
2. $(w_i + w_j)_{13}$ (from the ways m_{11} and m_{13}) = 1,1
3. $(w_i + w_j)_{14}$ (from the ways m_{11} and m_{14}) = 1,5
4. $(w_i + w_j)_{23}$ (from the ways m_{12} and m_{13}) = 0,9
5. $(w_i + w_j)_{24}$ (from the ways m_{12} and m_{14}) = 1,3
6. $(w_i + w_j)_{34}$ (from the ways m_{13} and m_{14}) = 0,8

And finally:

$$O_o = \frac{\sum_{i=1}^{y-1} \sum_{j=i+1}^y (O_{ij}(w_i + w_j))}{(y-1) \sum_{i=1}^y w_i} = \frac{0 + 0 + 1,164 * 1,5 + 0 + 0,977 * 1,3 + 0,1 * 0,8}{3 * (0,9 + 0,7 + 0,2 + 0,6)} = \frac{1,746 + 1,27 + 0,08}{7,2} = 0,43 \quad (10)$$

Thus put-option to abandon the “Photocatalytic isotope separation with the semiconductor nanoparticles application” project in 3 years costs 430 thousand of rubles **if first R&D-stage is success.**

Step 5 – Iterative WAPOPM application in all subtrees gives us put-option value at the initial time to abandon the project in 3 years. It equals to 251 thousand of rubles (Figure 8).

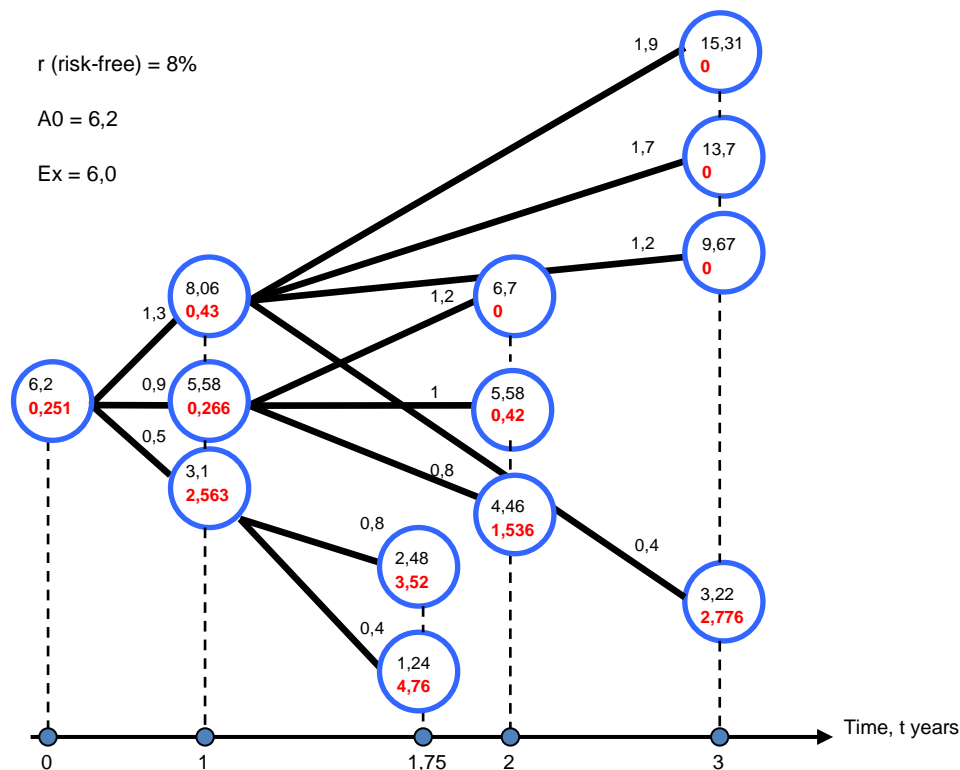

Figure 8. Step 5 - Final WAPOPM valuation.

It seems the most difficult point in our methodology (research limitation of this paper) it is parameters m_i estimation, which reflects basic asset price change. We suggest using Fuzzy Sets Theory in case of poor statistic data.

5. Conclusions and Extensions.

The valuation of the real options in the high-cost innovation-based investment projects with extended uncertainty is an important problem in practice. In this paper we study traditional methodology for R&D projects valuation, analyze assumptions, mark out weaknesses and develop a novel approach to valuate real options. Weighted Average Polynomial Option Pricing Model (WAPOPM) seemed to be more precise model because:

- in contrast to DCF method it takes into account investors' flexibility and it calculates investment risk by the scenarios tree (decision tree);
- in contrast to Black-Scholes Option Pricing Model (BSOPM) it doesn't need to estimate volatility parameter, σ and it is based on discrete time assumption;

- in contrast to Cox-Ross-Rubinstein Binomial option pricing model (BOPM) it is based on the polynomial changes;
- in contrast to difficult and strong mathematic models it can be easily used by financial managers in practice.

It is very important and interesting to scrutinize in the further research such questions as:

- a comparison of results from BSOPM, BOPM, Monte-Carlo method, Fuzzy ROV, WAPOPM;
- an attribute of the additiveness for several Real Options in one investment project.

References.

1. Black F., Scholes M. The Pricing of Options and Corporate Liabilities // The Journal of Political Economy. - May - Jun. 1973. - T. 81, No. 3. - pp. 637-654.
2. Bastian-Pinto C., Brandao L.E., Hahn W.J. - A Non-Censored Binomial Model for Mean Reverting Stochastic Processes - Annual International Conference "Real Options. Theory meets practice", 2010.
3. Cox J., Ross S., Rubinstein M. Option Pricing: A Simplified Approach // Journal of Financial Economics. - September 1979.
4. Ettlie J.E. – R&D and Global Manufacturing Performance Approach // Management Science. - #44: pp 1-11.
5. Grillo S., Blanco G., Schaerer C.E. - Real options using a Continuous-state Markov Process Approximation - Annual International Conference "Real Options. Theory meets practice", 2011.
6. Hull J.C. Options, Futures and Other derivatives. - Prentice Hall. - 5th Edition : pp. 756.
7. Leslie K.J., Michaels M.P. The Real Power of Real Options // The McKinsey Quarterly. - Number 3 1997.
8. Pennings E., Sereno L. - Evaluating pharmaceutical R&D under technical and economic uncertainty Processes - Annual International Conference "Real Options. Theory meets practice", 2010.
9. Trigeorgis L. Real Options. - Cambridge, MA, The MIT Press, 1996.
10. Tsujimura M. – Assessing Alternative R&D Investment Projects under Uncertainty Processes - Annual International Conference "Real Options. Theory meets practice", 2010.
11. Turnbull S.M. Option Valuation.- N.Y., Holt, Rinehart and Winston, Dryden Press, 1987.
12. Wilmott P., Howison S., Dewynne J. The Mathematics of Financial Derivatives. A Student Introduction. - Cambridge, Cambridge Univ. Press, 1995.
13. Russian Innovation Contest. URL: <http://www.inno.ru/>

Appendix 1. Incorrectness of the risk calculation in the denominator. A simple Example.

	Years, t						
	0	1	2	3	4	5	6
Cash In-Flow		2 500	3 200	3 200	3 200	3 200	3 200
Cash Out-Flow	-1 100	-1 800	-1 800	-1 800	-4 200	-4 200	-4 200
NCF	-1 100	700	1 400	1 400	-1 000	-1 000	-1 000
$(1+r(\text{risk-free}))^t$	1	1,10	1,21	1,33	1,46	1,61	1,77
NPV (risk-free)	-123,18						
$(1+r(\text{risk-free})+r(\text{risk}))^t$	1	1,19	1,42	1,69	2,01	2,39	2,84
NPV (risk)	37,79						

$r(\text{risk-free}) = 10\%$

$r(\text{risk}) = 9\%$

$(1+r(\text{risk-free})+r(\text{risk})) = 19\%$

NPV (risk) > NPV (risk-free)

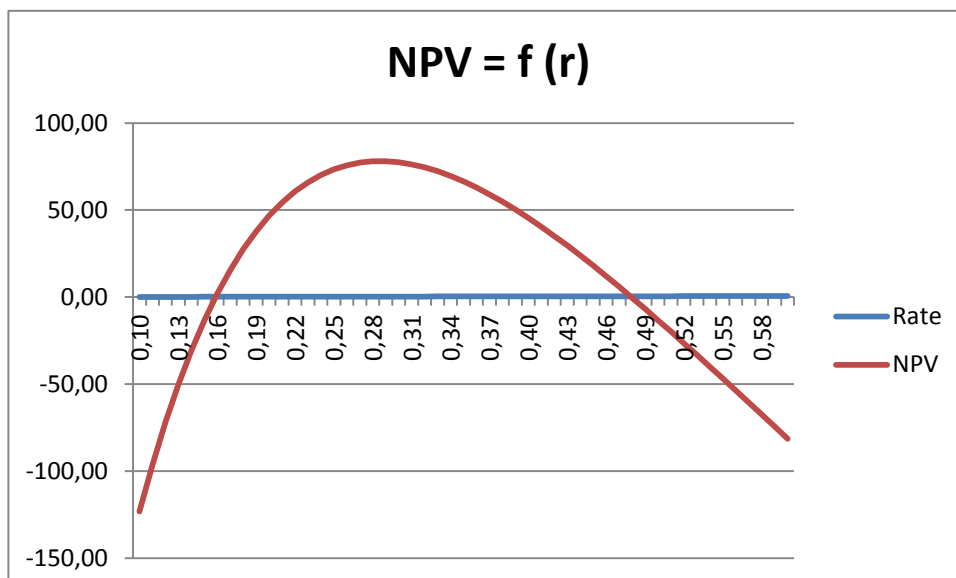

Appendix 2. Weaknesses in the traditional valuation methods concerning R&D projects.

Method	DCF Method			
DCF Weaknesses	Failure to take Investors' flexibility into account	Incorrectness of the risk calculation in the denominator by the cumulative discounting rate		
	↓	↓		
Method	BSOPM			
DCF Weaknesses Solution	Real Option Valuation	Risk calculation by the volatility parameter, σ		
BSOPM Weaknesses		Hard to estimate volatility parameter, σ in the practice	Continuous time assumption	
	↓	↓	↓	
Method	BOPM			
DCF Weaknesses Solution	Real Option Valuation	Risk calculation by the scenarios tree (decision tree)		
BSOPM Weaknesses Solution		We don't need to estimate volatility parameter, σ	Discrete time assumption	
BOPM Weaknesses				Based just only on the binomial changes
	↓	↓	↓	↓
	New Method			
New Method Should	Real Option Valuation	Risk calculation by the scenarios tree (decision tree). We don't need to estimate volatility parameter, σ	Discrete time assumption	Based on the polynomial changes

Appendix 3. Cox-Ross-Rubinstein Binomial option pricing model (BOPM) is the case of the WAPOPM where “y” equals 2.

$$\begin{aligned}
 O_{o|y=2} &= \frac{\sum_{i=1}^{y-1} \sum_{j=i+1}^y (O_{ij}(w_i + w_j))}{(y-1) \sum_{i=1}^y w_i} \quad |y=2 \\
 &= \frac{O_{12}(w_1 + w_2)}{(w_1 + w_2)} = \\
 &= O_{12} \equiv O_{ud} = \\
 &= \frac{pO_u + (1-p)O_d}{(1+r_{\text{free}})^t}
 \end{aligned}$$